

Pre-Installation Specifications Modbar EP

Instructions for plumber, electrician, architect or designer, outlining the specific requirements PRIOR TO INSTALLATION of the Modbar EP Espresso System.

Prepare your site for the installation of one or more tap(s) and a drip tray(s) in the countertop surface and one or more module(s) on a well-ventilated shelf or rack directly below.

Designer or Architect Specifications – Above Counter

- A dry, well-ventilated counter area, which is between 800mm and 950mm high, with a depth of at least 500mm.
- An area to be provided next to the machines for a grinder and working area. To maintain a clean look, we recommend considering grinder placement and location. Building a drop into the countertop between 100-200mm can be effective.
- 38mm and several smaller holes drilled through the countertop for each tap and appropriate holes cut for each drip tray. Cuts should be made prior to the installation using the Modbar EP layout template.
- If installing multiple taps, leave 300mm between center holes on adjacent taps.

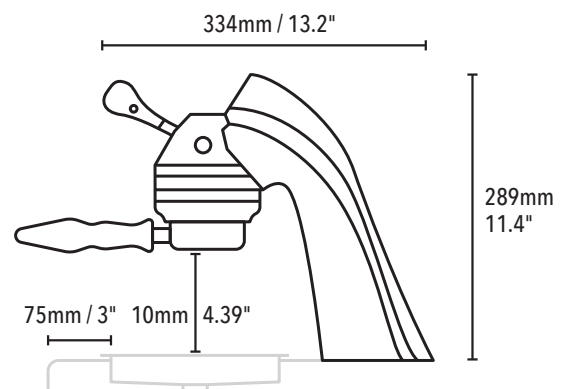
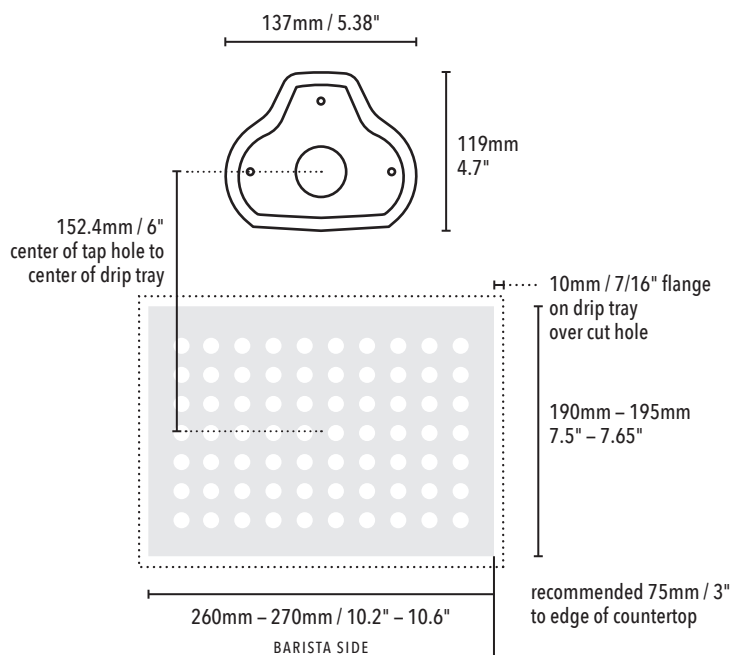

Designer or Architect Specifications – Below Counter

- Cabinet space should have a depth of at least 500mm and a width of at least 690mm to allow for clearance around and behind the modules.
- Shelves or a wire rack should be provided to support each module.
- Rear access to modules recommended whether through sliding doors or removable panels.
- We do not recommend installing cabinet doors in this space.
- Cafe owner should consider where filtration will go. Water filtration is required for all coffee equipment.

Water Specifications

Your filtration system should produce water with the following properties:

T.D.S.	90–150ppm
TOTAL HARDNESS	70–100 ppm
TOTAL IRON	0–0.02ppm
FREE CHLORINE	0–0.05ppm
TOTAL CHLORINE	0–0.1ppm

PH	6.5–8
ALKALINITY	40–80ppm
CHLORIDE	0–30ppm
LINE PRESSURE	3–5 bar
FLOW RATE	2 GPM/8 LPM

Module Dimensions & Specifications

MODULE	WIDTH (+CLEARANCE)	DEPTH (+CLEARANCE)	HEIGHT (+CLEARANCE)	WEIGHT	VOLTAGE	RECEPTACLE	WATTAGE
Espresso EP	406mm (+150mm)	356mm (+150mm)	137mm (+75, or 150mm)	14 kg	208-240V	16A CEEFORM socket	3200

Required Module Clearance

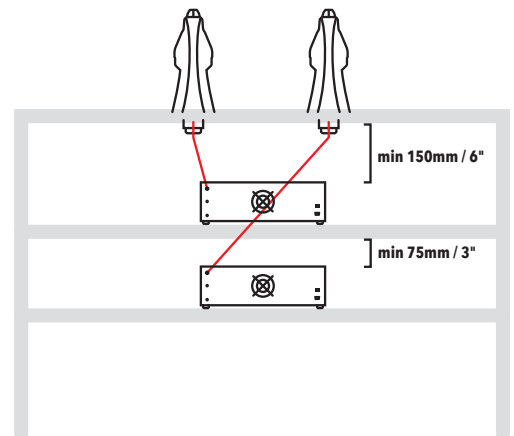
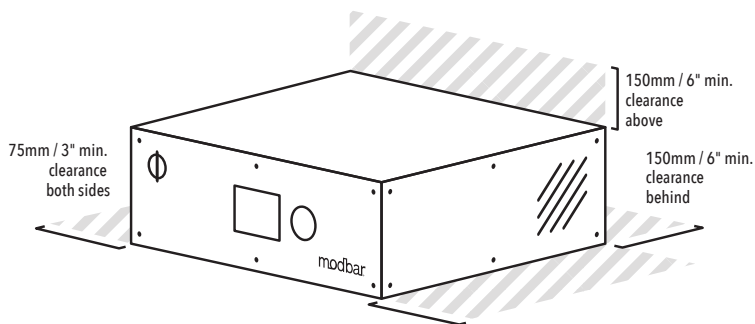

Plumber Specifications

- **Each module** requires a stop valve, with a flow rate of at least 4 litres per minute.
- Pressure between 3 bar and 5 bar. If pressure is too high i.e. >5 bar, pressure regulator is required.
- Owner should communicate with equipment installer about water filtration requirements. Talk with your sales representative for more information.

Waste Outlet

- Drain connection is 1/4" female pushfit.
- Open gravity drain of minimum 32mm interior diameter within 1m of module(s).
- Drain must be located lower than the placement of the bottom-most module in your Modbar system. There should be no less than 25mm per 300mm downward slope in drain line.

Electrician Specifications

- The electrical requirements are 208-240 Volt single-phase, 50-60hz supply with 16A **per module**. (Subpanels are useful in multiple-module installations.)
- All modules will be supplied with an appropriate plug end on the power cord. Receptacle should be no further than 1.5m from the modules, with the electrician responsible for installation of appropriate socket.

